

® **INREKA PLOŠINY**

IPT 16-1

BASIC INFORMATION

The work platform is with telescopic draw-out four-part arm. Little superstructure proportions make possible its installation on majority commercial motor vehicle to the maximum total weight 3850 kg. Installation is for road but for off-road operation too. The work cage is in standard design without turning. Working cage can be provided option with turning arrangement. The turntable is with unrestricted turning. Four hydraulic operated props are served for stability. The work platform is made with dual insulation for work under voltage up to 1000V.

On undercarriage vehicle body suspension can be direct or with possibility demountable superstructure. Accession to work cage is possible from floor frame base or the ground. Two cases for placing implements are on frame the work platform.



HYDRAULIC SYSTEM

All working movements are provided hydraulic. All hydraulic cylinders have security hydraulic locks. Operating working movements turntable and arms is possible opt place from turntable or from working cage. Drive working movements is proportional with preselection movements.

DRIVE HYDRAULIC PUMP

The pump drive is induced from vehicle engine. The vehicle engine is possible conk out and start from working cage. Hydraulic pump can be driven by elektromotor 230V/50Hz too. This elektromotor power supply from public net or from electric generator. Next possible drive is by electric motor DC 12V. This electric motor power supply from accumulator batteries.

CARRIAGE UNIT

The work platform is possible mount on any undercarriage, where undercarriage has capacity weight except crew minimum 2000 kg. On the picture the work platform is mounted on undercarriage SCAM and undercarriage is tight linked to work platform. The work platform can be solving constructional as the work platform dismountable.

TECHNICAL DATA

Transport measurement:

- size 6,6m
- width 2,4m
- height 3,05m

Work reach:

- height 16,8m
- side reach 8,0m
- turning no limits
- width props 3,7m

Work cage:

- proportions 0,7 x 1,1 m
- maximum load 250kg+10%

Weight:

- platform without undercarriage 1755kg
- undercarriage SCAM 2520kg
- curb weight with driver 4275kg

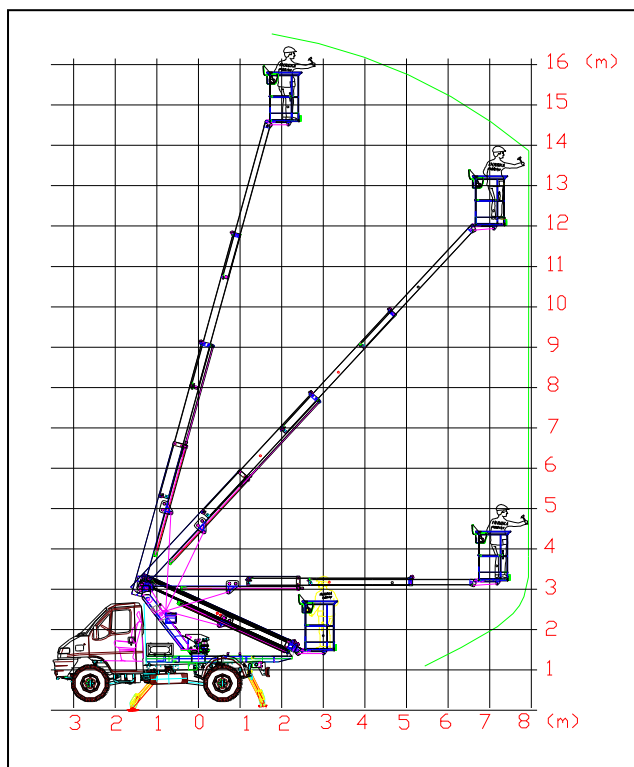

Working diagram

SAFETY EQUIPMENT

The mechanical limitation end position of all arms. The hydraulic cylinders are procurement locks. The hand emergency pump. The equipment against overfreight working cage. The switch knob „TOTAL STOP“, the activity truck body is bound on vehicle stabilization. Dual insulation to the 1000V.

EQUIPMENT OPTIONS

Alternative drive by electric motor 230V/50Hz. Alternative drive DC 12V electric motor energize from accumulator batteries. The electric generator 230V/50Hz – 2,2kW. Laminate working cage for increasing safeness under voltage.

SUPPLIER

INREKA PLOŠINY
Uherský Brod
Rudice 231
687 32 Nezdenice

tel.: (+420) 572 637 722
(+420) 572 630 339
(+420) 603 803 192
(+420) 774 949 385
fax: (+420) 572 630 343

e-mail: inreka@inreka-plosiny.cz
<http://www.inreka-plosiny.cz>